

SERVICE VALVE

With internal and external threads / ISO-fitting



Design features

- Resilient seated gate valve with smooth straight-through bore
- Internal thread ISO 228, external thread EN 10226-1
- Service valve fitted with a corrosion protection ring to prevent corrosion
- For service valves with external thread, the free lying threads must be protected against corrosion according to the trade regulations after assembly
- **No. 2800:** Internal thread for assembly of a drilling machine for drilling under pressure
- For PE-pipes according to EN 12201 and DIN 8074 | to PN 16; up to 30° C medium temperature
Pipe guide nipple serves for precise guidance of the PE pipe and as corrosion protection of the internal thread

Standard version: without handwheel and extension spindle

Special versions: on request

Material | Technical features

- **Body and bonnet** made of ductile iron
- **Corrosion protection ring** made of elastomer
- **Pipe guide nipple** made of PE

Suitable accessories

Suitable accessories: see page J 1/2

Handwheel:		No. 7800
Extension spindle:	rigid	No. 9101
	telescopic	No. 9601
Surface box:	rigid	No. 1550, No. 1650
	telescopic:	No. 1850, No. 1851K
Spindle extension:	No. 7820	
Sealing cap:	No. 2156, No. 2157, No. 2158	
Chamfering tool:	No. 6000	
Saddle blades:	No. 6010	
Pipe cutter:	No. 6050	
Mounting spray:	No. 3443	
Drilling machine:	No. 5800, No. 5805	

No. 2520



No. 2800



STRUCTURE of grip ring for PE pipes



Order No.	Version	MOP (PN)	Dimensions/DN			
			1"	1¼"	1½"	2"
2520	1 internal thread	16				
	1 external thread					
2800	1 external thread					
	1 ISO-fitting for PE pipe 1 internal thread					

No. 2800 can be adapted for PVC pipe with carborundum grip ring at extra cost

Application example

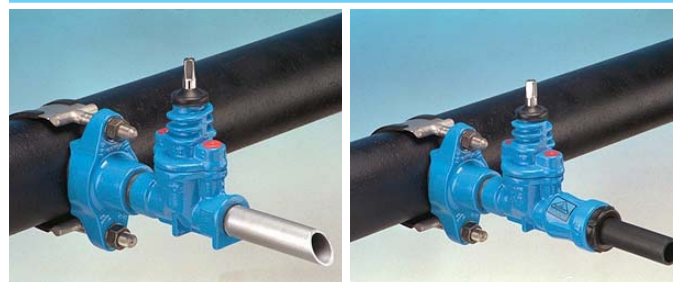

E. Hawle Armaturenwerke GmbH 4840 Vöcklabruck - Austria - Wagrainstraße 13
Tel.: +43 (0) 7672 72576 0 - Fax: +43 (0) 7672 78464 - E-Mail: hawle@hawle.at - www.hawle.com

J 4/3

SERVICE VALVE

With internal and external threads / ISO-fitting



Service valve, ductile iron

With one internal thread ISO 228 and one external thread EN 10226-1

No. 2520

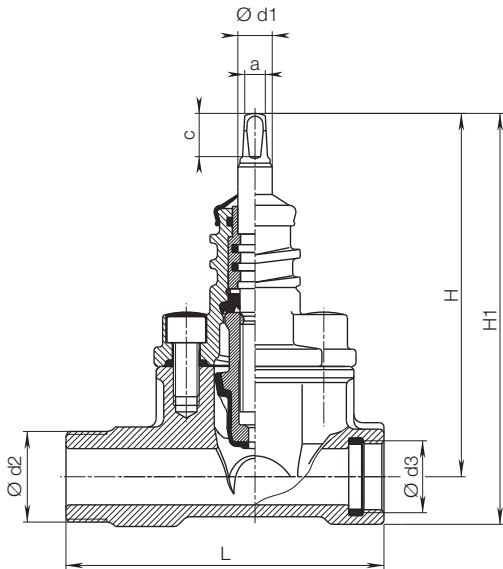

DN	Valve					Spindle			Weight
	Ø d2	Ø d3	L	H	H1	a	c	Ø d1	
1"	1 1/4"	1"	148	164	191	10,3	20	16	2,40
1 1/4"	2"	1 1/4"	167	200	234				3,80
1 1/2"	2"	1 1/2"	167	200	238				4,00
1 1/2"	1 1/2"	1 1/2"	167	200	238				4,00
2"	2"	2"	172	219	264				4,60

Service valve, ductile iron

1 external thread EN 10226-1, 1 ISO-fitting, 1 internal thread ISO 228

No. 2800

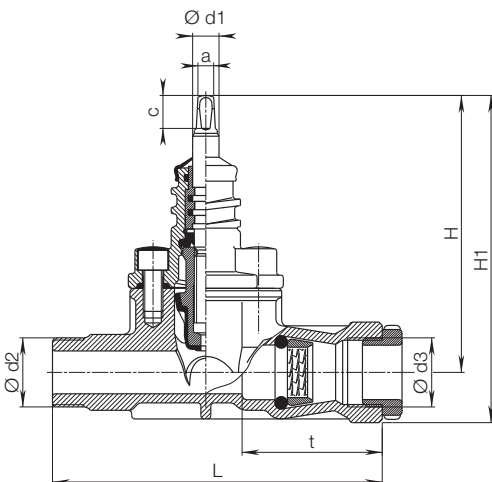

DN	Valve							Spindle			Weight
	Ø pipe ext.	Ø d2	Ø d3	t	L	H	H1	a	c	Ø d1	
1"	32	1 1/4"	1 1/4"	85	200	164	193	10,3	20	16	2,72
1 1/4"	40	2"	1 1/2"	101	245	200	234				4,46
1 1/2"	50	2"	2"	121	255	200	239				4,90
2"	63	2"	2 1/2"	137	264	219	267				6,81

J 4/4



E. Hawle Armaturenwerke GmbH 4840 Vöcklabruck - Austria - Wagrain Straße 13
 Tel.: +43 (0) 7672 72576 0 - Fax: +43 (0) 7672 78464 - E-Mail: hawle@hawle.at - www.hawle.com