

Bends

BPL-90



Description

BPL – pressed bend, seam-welded and calibrated, with double EPDM gasket.

$$r_m \gg 1 \times d_1$$

Example identification

Product code: **BPL - aaa - 90**

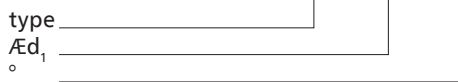

Technical Data

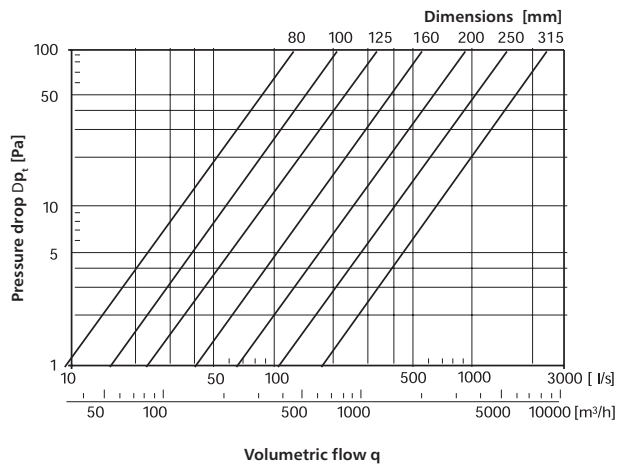

Dimensions

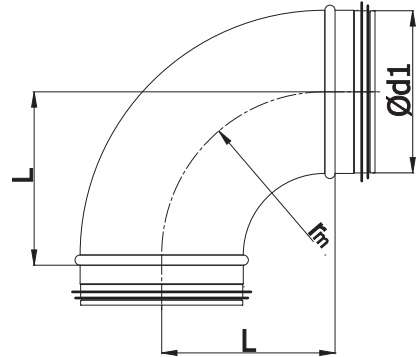

$$r_m \gg 1 \times d_1$$

$\text{Æ}d_1$ rated [mm]	L [mm]	weight [kg]
80	100	0,3
100	100	0,4
125	125	0,6
140	135	0,8
150	150	0,9
160	160	1,0
180	175	1,2
200	200	1,5
250	250	2,4