

Bends

BPL/BP-30



Description

BPL – pressed bend, seam-welded and calibrated, with double EPDM gasket.
 BP – pressed bend, seam-welded and calibrated, without gasket.

Example identification

Product code: **BPL - aaa - 30**

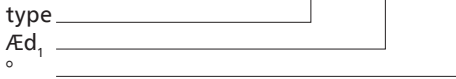

Technical Data

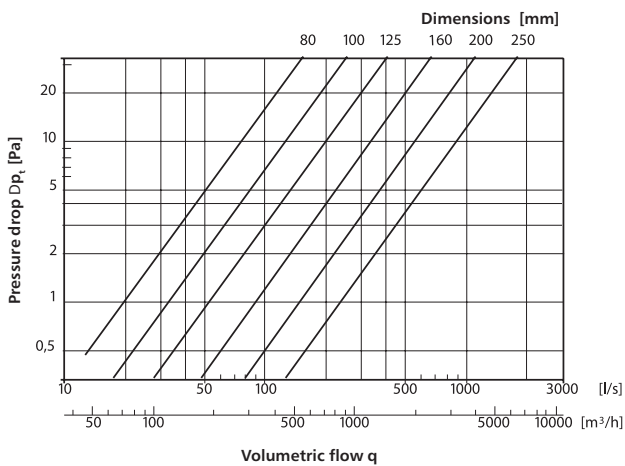

Dimensions

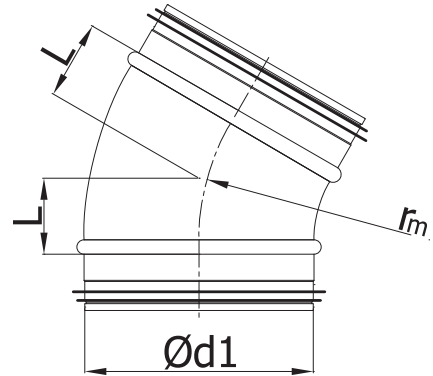

$r_m \gg 1 \times d_1$

$\text{\AA}d_1$ rated [mm]	L [mm]	weight [kg]
80	27	0,2
100	27	0,3
125	33	0,3
140	36	0,4
150	40	0,4
160	43	0,5
180	48	0,6
200	54	0,7
250	67	1,4