

Supply Air Valves

KN



Description

The KNI air supply valve is designed for mounting on ceilings, walls or directly on ducts with use of the special assembly frame RM. The KNI valve has a continuous adjustment of inlet air by rotating central disc. Selected slot can be fixed by means of a fixing nut. Special construction of the valve ensures a low level of noise as well as easy and fast assembly.

Material: steel sheet

Furnishing: furnace enamelling

Standard colour: white

Example identification

Product code: KN - aaa

type _____
 $\varnothing d$ _____

* as standard complete with mounting frame

Technical Data

Parameters

Volumetric flow q (l/s or m³/h.), total pressure loss P_t (Pa) and acoustic pressure level L_A (dB(A)) for various cone settings can be read from the figure.

Pressure losses P_t

The figures show total pressure loss P_t (Pa).

Acoustic pressure level, L_A

The figure shows acoustic pressure level L_A (dB(A)). The noise level is specified for a room attenuation of 4dB, which translates into attenuation in the reverberation zone of the SABINE room with an acoustic absorption of 10 m²

Control

Details of how to control volumetric flow are to be found in the instructions for use.

Dimensions

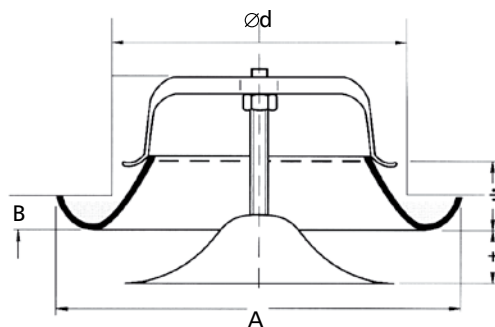

$\varnothing d$ nom [mm]	A [mm]	B [mm]	weight [kg]
80	115	12	0,15
100	137	12	0,19
125	164	12	0,31
150	202	12	0,35
160	212	12	0,47
200	248	12	0,66
250	302	12	0,88

Acoustic pressure level L_A (dB(A))

dimension [mm]	average frequency (Hz)						
	125	250	500	1000	2000	4000	8000
80	6	3	2	1	-4	-16	-20
100	4	3	2	0	-7	-15	-30
125	2	7	3	-2	-10	-20	-32
160	5	7	3	-2	-10	-19	-32
200	8	6	4	-3	-10	-19	-32
250	9	8	6	-4	-12	-20	-33
tolerance	3	2	2	2	2	2	3

Sound attenuation (dB)

dimension [mm]	average frequency (Hz)							
	63	125	250	500	1000	2000	4000	8000
80	22	19	14	11	2	3	7	8
100	22	16	11	8	6	6	3	6
125	20	15	9	6	4	3	3	5
160	18	13	8	5	4	4	5	6
200	17	11	7	6	6	5	6	6
250	18	12	9	7	7	6	7	5
tolerance	6	3	2	2	2	2	2	3

Roof Valves KN, KN-S

Technical Data

Selection charts

