

Data sheet

Multifunctional Thermostatic Circulation Valve

MTCV - Lead free brass

Introduction

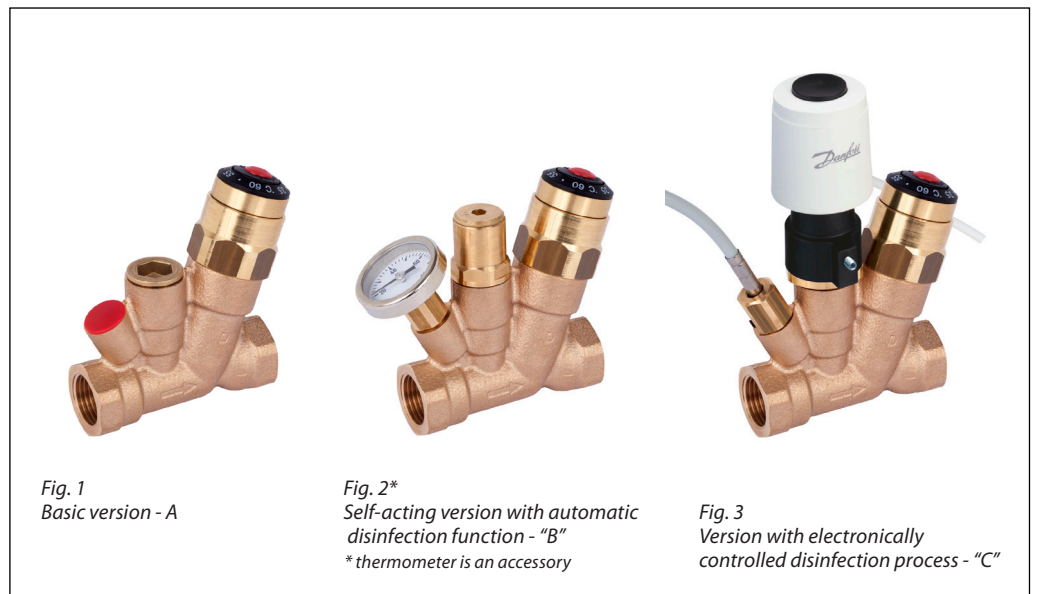

The MTCV is a multifunctional thermostatic balancing valve used in domestic hot water installations with circulation.

The MTCV provides a thermal balance in hot water installations by keeping a constant temperature in the system, thus limiting the flow in the circulation pipes to the minimum required level.

To meet the increasing demands placed on the quality of drinking water, Danfoss MTCV valves are made from corrosion resistant and Lead Free

materials:

- valve body made from rg5 bronze material
- components made from no Lead Brass
- main cone made from advanced engineering polymere POM-C.

Simultaneously, the MTCV can realize a disinfection process by means of 2 features:

- An automatic (self-acting) disinfection module - thermo-element (fig.2).
- An electronic controller with thermal actuator TWA and temperature sensors PT1000 (fig.3).

Main functions of the MTCV

- Thermostatic balancing of hot water systems within the temperature range of 35 - 60 °C - version A.
- Automatic (self-acting) thermal disinfection at temperatures above 68°C with safety protection of the installation to prevent the temperature rising above 75 °C (automatically shuts-off circulation flow) - version "B".
- Automatic disinfection process, electronically controlled, with the possibility of programming the disinfection temperature and duration - version "C".
- Automatic flushing of the system by temporarily lowering the temperature setting to fully open the MTCV valve for a maximum flow.
- Temperature measurement possibility.
- Preventing of unwanted tampering.
- Constant temperature measurement and monitoring - version "C".
- Shut-off function of the circulation riser by means of optional fittings with a built-in ball valve.
- Modular upgrading of the MTCV valve during operation, under pressurized conditions.
- Servicing - when necessary the calibrated thermo-element can be replaced.

Function



Fig. 4 MTCV basic version - A

The MTCV - is a thermostatic self-acting, proportional valve. A thermo-element (fig. 6 elem. 4) is placed in the valve cone (fig. 6 elem. 3) to react to temperature changes.

When increases the water temperature above the set point value, the thermo-element expands and the valve's cone moves towards the valve seat, thus limiting circulation flow.

When decreases the water temperature below the set point value, the thermo-element will open the valve and allow more flow in the circulation pipe. The valve is in equilibrium (nominal flow = calculated flow) when the water temperature has reached the value set on the valve.

The MTCV regulating characteristic is shown in fig. 13, version A.

When the water temperature is 5 °C higher than the set point value, the flow through the valve stops.

A special sealing of the thermo-element protects it against direct contact with water, which prolongs the durability of the thermo-element and at the same time secures a precise regulation.

A safety spring (fig. 6 elem. 6) protects the thermo-element from being damaged when the water temperature exceeds the value on the set point.

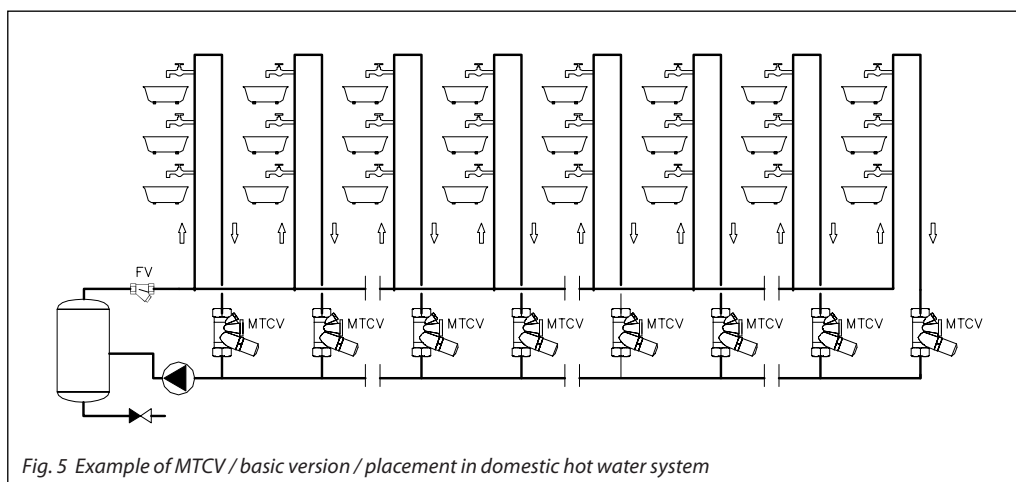

Fig. 5 Example of MTCV / basic version / placement in domestic hot water system

Design

1. Valve body
2. Spring
3. Cone
4. Thermo-element
5. O-ring
6. Safety spring
7. Setting ring
8. Setting knob
9. Plug for covering the setting
10. Cone for disinfection module
11. Safety spring
12. Plug for thermometer
13. Plug for disinfection module

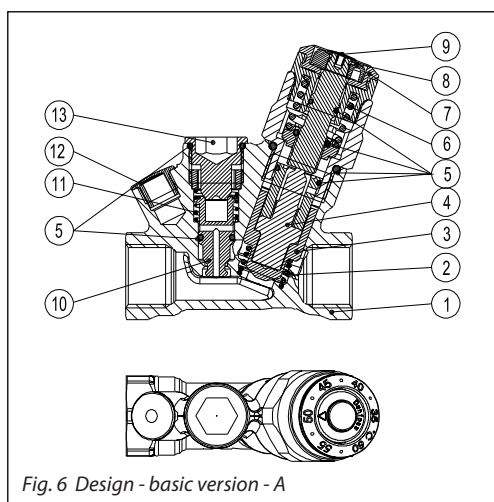

Fig. 6 Design - basic version - A

Function



The mounted disinfection module automatically opens a by-pass of Kv min = 0.15 m³/h, which allows flow for the disinfection. In the A version of the MTCV this by-pass is always closed in order to avoid sedimentation of dirt and calcium. The MTCV can thus be upgraded with the disinfection module even after a long period of working in the A version without risking blocking the bypass.

The regulation module in basic version A works within the temperature range 35-60 °C. When the temperature of the hot water increases above 65°C the disinfection process starts - meaning the flow through the main seat of the MTCV valve stops and the bypass opens for the "disinfection flow". The regulating function is now performed by the disinfection module, which opens the bypass when the temperature is above 65 °C.

The MTCV standard version - A can easily and quickly be upgraded to the thermal disinfection function against the Legionella bacteria in hot water systems.

After removing the plug from the disinfection plug (fig. 6 elem. 13)-(this can be done during working conditions, under pressure) the thermostatic disinfection module can be mounted (fig. 9 elem. 17).

The disinfection module will control the flow according to its regulating characteristics, (fig. 13, vesion B) thus performing a thermal disinfection of the hot water installation.

The disinfection process is performed until a temperature of 70 °C is reached. When the hot water temperature is increased further, the flow through the disinfection bypass is reduced (the process of thermal balancing of the installation during disinfection) and when reaching 75 °C the flow stops. This is to protect the hot water installation against corrosion and sedimentation of calcium as well as to lower the risk of scalding.

A thermometer can optionally be mounted in both version A and B in order to measure and control the temperature of the circulating hot water.

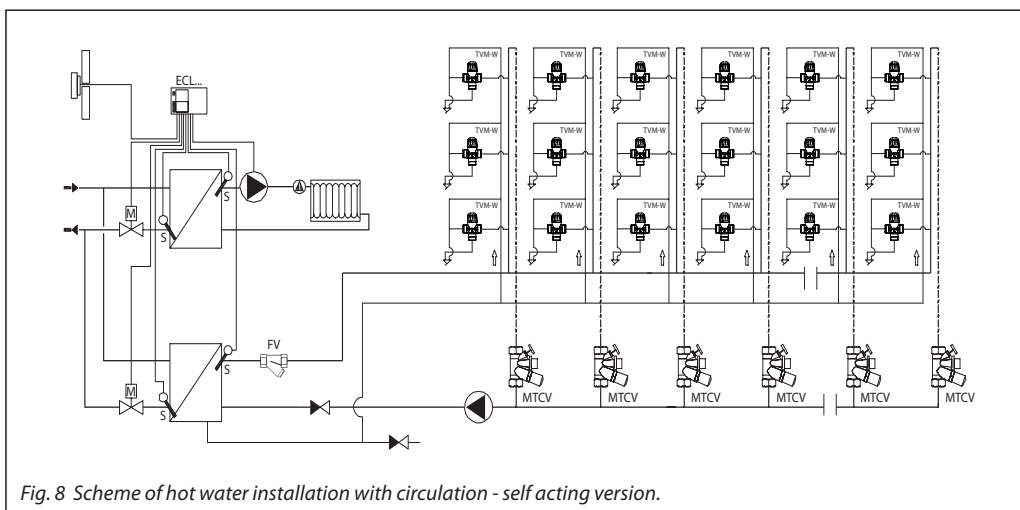

Design

- 1-13As described in fig. 6
- 14 Bypass for disinfection
- 15 Thermometer
- 16 Gasket Cu
- 17 Disinfecting module

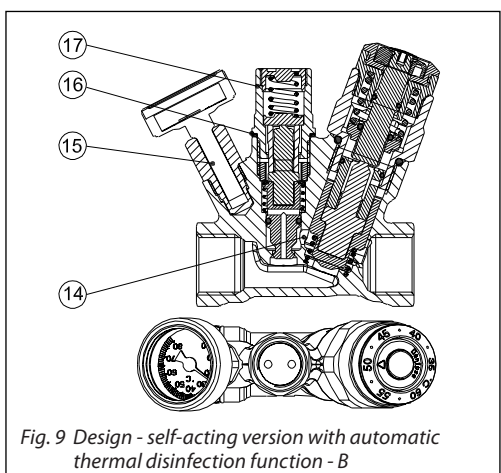

Function



Fig.10 Version with electronically controlled disinfection process - C

A temperature sensor PT 1000 has to be mounted in the thermometer head (fig. 12 elem. 19). Thermo-actuator and sensor are connected to the electronic regulator CCR-2 which allows an efficient and effective disinfection process in each circulation riser. The main regulation module works within the temperature range 35-60 °C. When the disinfection process/thermal-water treatment starts CCR-2 controls the flow through MTCV via thermo-actuators TWA. Benefits of an electronic regulated disinfection process with CCR-2 are:

- Providing full control over the disinfection process in each individual riser.
- Optimisation of total disinfection time.
- Optional choice of temperature for the disinfection.
- Optional choice of time for the disinfection.
- On-line measurement and monitoring of the water temperature in each individual riser.
- Enabling the possibility of connecting to the controller in the heat substation or boiler room (i.e. Danfoss ECL) or to a BMS (RS 485).

The MTCV version "A" and "B" can be upgraded to an electronic regulated disinfection process (version C).

After removing the disinfection plug (fig. 6 elem. 13) the adapter can be mounted (fig. 12 elem. 21) and the thermo actuator TWA can be mounted.

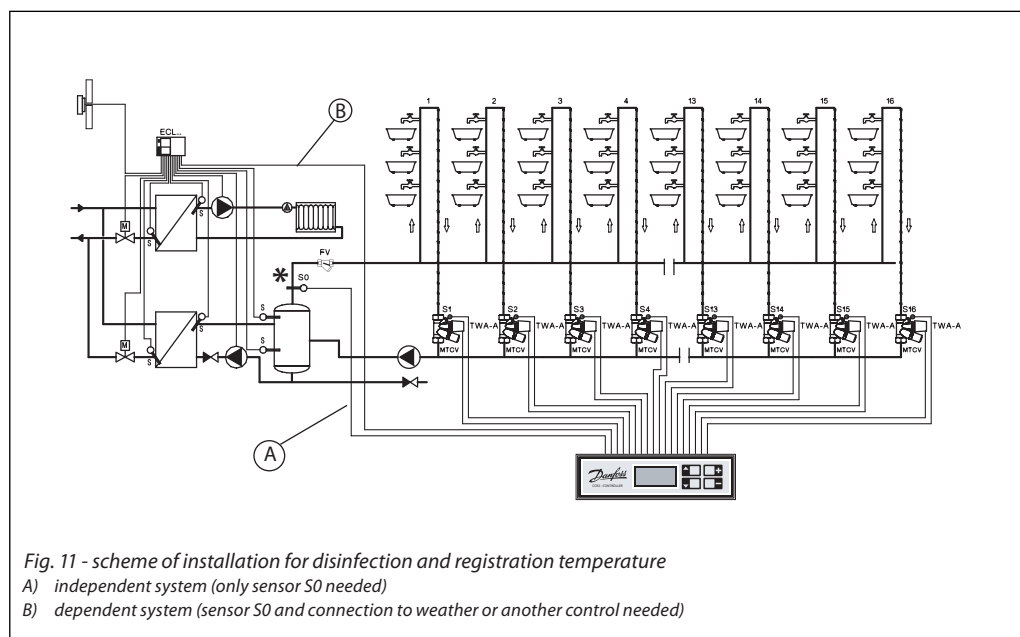

Fig. 11 - scheme of installation for disinfection and registration temperature
 A) independent system (only sensor S0 needed)
 B) dependent system (sensor S0 and connection to weather or another control needed)

Design

- 1-13 As described in fig. 6
- 18 Bypass; (position closed)
- 19 Temperature sensor PT 1000
- 20 Gasket Cu
- 21 Adapter to connect thermo-actuator TWA

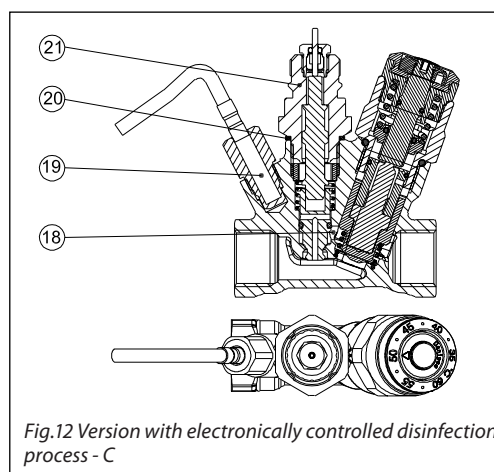

Fig.12 Version with electronically controlled disinfection process - C





Data sheet
Multifunctional Thermostatic Circulation Valve MTCV- Lead free brass
Technical data

Max. working pressure.....	10 bar	<i>Material of parts in contact with water:</i>
Test pressure.....	16 bar	Valve body
Max. flow temperature	100 °C	Spring housing, etc.
k_{VS} at 20 °C:		O-rings
- DN20	1.8 m ³ /h	Spring, bypass cones
- DN15.....	1.5 m ³ /h	Cone.....
Hysteresis.....	1.5 K	

Ordering

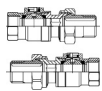
Valve - basic version A	Code No.
DN 15	003Z4515
DN 20	003Z4520

Accessories and spare parts

Accessory		Comments	Code No.
Thermostatic disinfection module - B		DN 15/DN 20	003Z2021
Fittings with shut-off ball valve (for allen key 5 mm), DN 15		G 1/2 x Rp 1/2	003Z1027
		G 3/4 x Rp 3/4	003Z1028
Thermometer with adapter		DN 15/DN 20	003Z1023
Socket for ESMB PT1000		DN 15/DN 20	003Z1024
Adapter for thermo-actuator		DN 15/DN 20	003Z1022
CCR 2 Control		also see enclosure VD.57.U4.02	003Z3850
Temperature sensor ESMB Universal		also see enclosure VD.57.U4.02	087B1184
Temperature sensor ESMC contact			087N0011
Fittings for soldering Cu 15 mm		DN 15	003Z1034
Fittings for soldering Cu 18 mm		int. R 1/2"	003Z1035
Fittings for soldering Cu 22 mm		DN 20	003Z1039
Fittings for soldering Cu 28 mm		int. R 3/4"	003Z1040
Thermoactuator TWA-A/NC, 24V ¹⁾		also see enclosure VD.57.U4.02	088H3110

¹⁾ For combination with other (non Danfoss CCR2) controllers 230V also available TWA-A/NC, 230V (008H3112).

Regulating characteristics

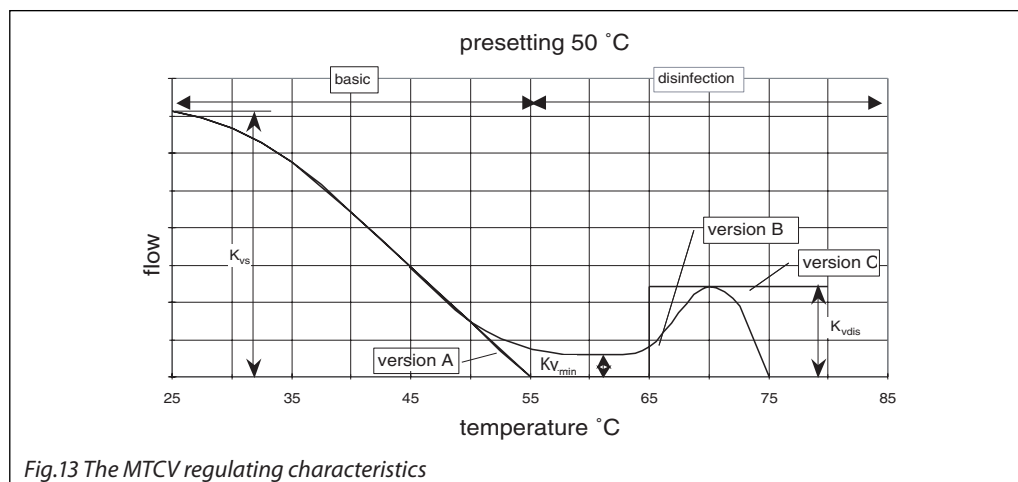

- Basic version A
- Version B:
 $Kv_{min} = 0.15 \text{ m}^3/\text{h}$ - min. flow through the bypass when main regulation module is closed.
 $*Kv_{dis} = 0.60 \text{ m}^3/\text{h}$ for DN 20,
 $*Kv_{dis} = 0.50 \text{ m}^3/\text{h}$ for DN 15 - max. flow of the disinfection process by a temperature of 70 °C.
- Version C:
 $*Kv_{dis} = 0.60 \text{ m}^3/\text{h}$ for DN 20 and DN 15 - flow through the MTCV when the disinfection module is fully opened (regulation at thermo-actuator TWA-NC).
 $*Kv_{dis}$ - Kv during disinfection process

Main function setting

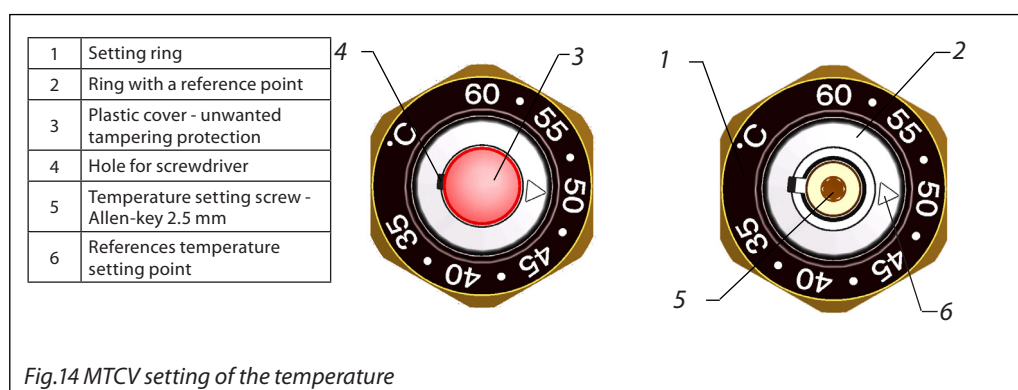

Temperature range: 35-60 °C
MTCV's factory pre-setting 50 °C

The temperature setting can be made after removing the plastic cover (3), by lifting it with a screwdriver using the hole (4). The temperature setting screw (5) must be turned with an allen-key to match the wanted temperature on the scale with the reference point. The plastic cover (3) must be pressed back into place after the setting has been made.

It is recommended to control the set temperature with a thermometer. The temperature of the hot water from the last tapping point on the riser must be measured*. The difference between the measured temperature at the last tapping point and the temperature set on the MTCV is due to heat losses in the circulation pipe between the MTCV and the tapping point.

* where TVM valves (thermostatic mixing valves) are installed the temperature must be measured before the TVM valve.

Setting procedure

The required temperature setting of the MTCV depends on the required temperature at the last tap and the heat losses from the tap to MTCV in the same riser.

Required:
correct setting of MTCV

Solution:
Correct setting of MTCV: $48 + 3 = 51\text{ }^{\circ}\text{C}$

Example:

Required temperature at the last tap: $48\text{ }^{\circ}\text{C}$
Heat losses from the last tap to the MTCV: 3 K

Note:
After new setting use the thermometer to check if the required temperature at the tap is reached and correct the MTCV setting accordingly.

**Pressure and flow chart
MTCV - DN 15**

Differential pressure 1 bar, DN 15

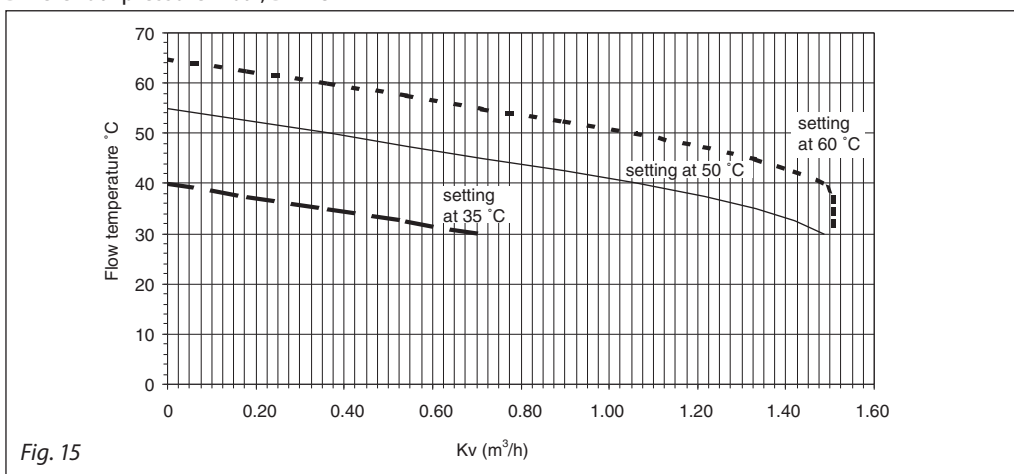

Fig. 15

Table 1

	preset	preset	preset	preset	preset	preset	kv (m³/h)
Flow temperature °C	60 °C	55 °C	50 °C	45 °C	40 °C	35 °C	0
	65	60	55	50	45	40	0.181
	62.5	57.5	52.5	47.5	42.5	37.5	0.366
	60	55	50	45	40	35	0.542
	57.5	52.5	47.5	42.5	37.5	32.5	0.711
	55	50	45	40	35	30	0.899
	52.5	47.5	42.5	37.5	32.5		1.062
	50	45	40	35	30		1.214
	47.5	42.5	37.5	32.5			1.331
	45	40	35	30			1.420
	42.5	37.5	32.5				1.487
	40	35	30				1.505
	37.5	32.5					1.505
35	30					1.505	
32.5						1.505	
30						1.505	

Differential pressure 1 bar, DN 15 - disinfection process

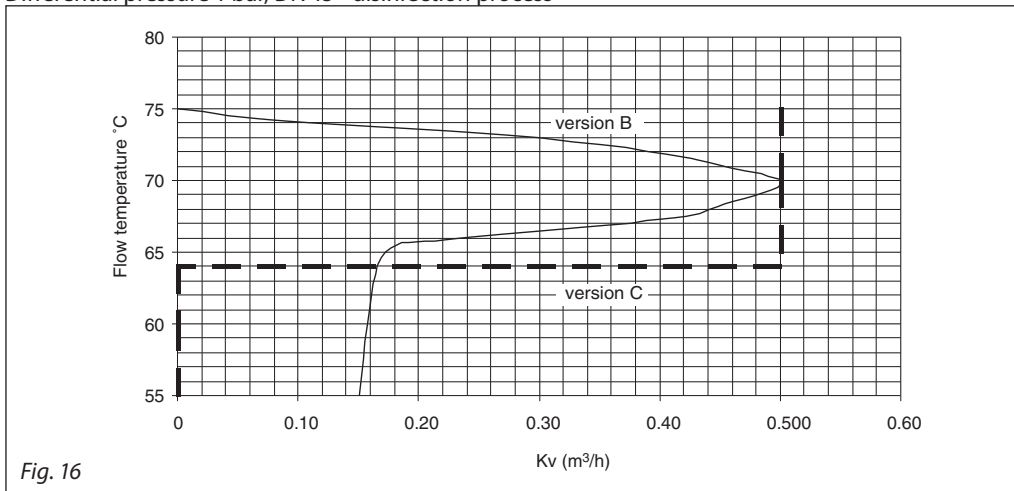

Fig. 16

Pressure and flow chart
MTCV - DN 20

Differential pressure 1 bar, DN 20

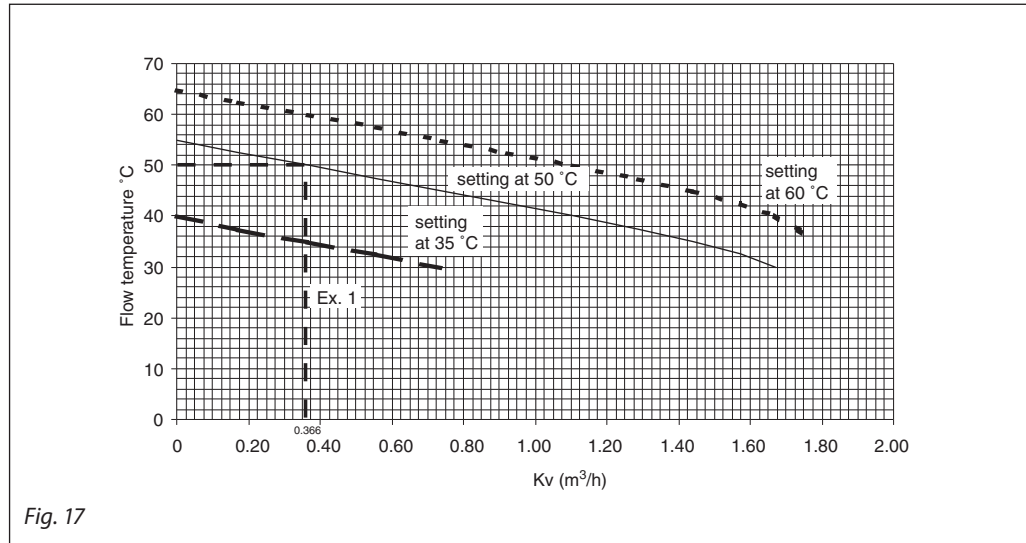

Table 2

Flow temperature °C	preset	preset	preset	preset	preset	preset	kv (m³/h)
	60 °C	55 °C	50 °C	45 °C	40 °C	35 °C	
65	65	60	55	50	45	40	0
62.5	62.5	57.5	52.5	47.5	42.5	37.5	0.172
60	60	55	50	45	40	35	0.336
57.5	57.5	52.5	47.5	42.5	37.5	32.5	0.556
55	55	50	45	40	35	30	0.738
52.5	52.5	47.5	42.5	37.5	32.5		0.921
50	50	45	40	35	30		1.106
47.5	47.5	42.5	37.5	32.5			1.286
45	45	40	35	30			1.440
42.5	42.5	37.5	32.5				1.574
40	40	35	30				1.671
37.5	37.5	32.5					1.737
35	35	30					1.778

Differential pressure 1 bar, DN 20 - disinfection process

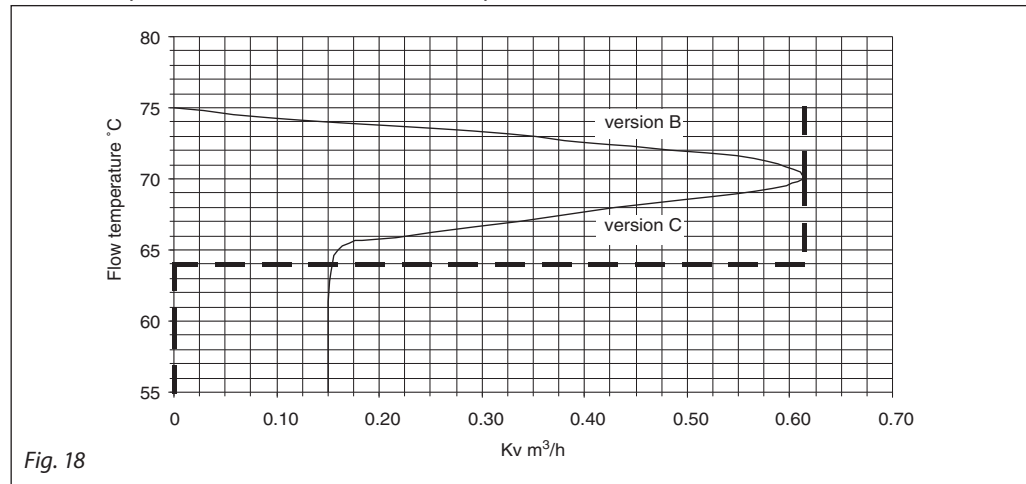

Fig. 18

Example of calculation

Example:

The calculation is done for a 3-storey building with 8 risers.

The following assumptions were used in order to simplify calculation:

- Heat losses per meter of the pipe, $q_1 = 10 \text{ W/m}$ (*)
 (* during calculation it is required to calculate heat losses according to the country-specific standards).

Usually the calculated heat losses are dependent on :

- The dimension of the pipe
- The materials used in insulations
- The ambient temperature where the pipe is located
- The efficiency and condition of insulation
- Inlet of hot water temperature, $T_{sup} = 55 \text{ }^\circ\text{C}$
- Temperature drop through the system, $\Delta T = 5 \text{ K}$
- Distance between risers, $L = 10 \text{ m}$
- Height of the risers, $l = 10 \text{ m}$
- Installation scheme as shown below:

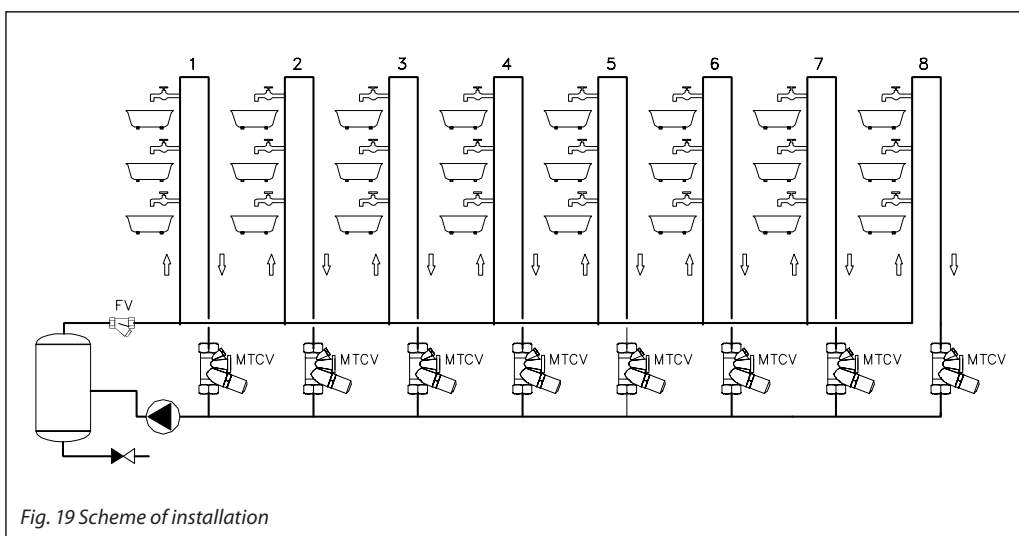

I Basic operation

Calculation:

- calculation of heat losses in each riser (Q_r) and header (Q_h)
 $Q_r = l \text{ riser} \times q = (10 + 10) \times 10 = 200 \text{ W}$
 $Q_h = l \text{ horiz.} \times q = 10 \times 10 = 100 \text{ W}$
- The table 3 shows the results of the calculations:

$$\begin{matrix} \rightarrow & \uparrow & \rightarrow \\ & \dot{V}_o & \\ \dot{V}_c & & \dot{V}_p \\ \dot{V}_c = \frac{\dot{V}_o}{\dot{V}_o + \dot{V}_p} \end{matrix}$$

Table 3

riser	heat losses				Factor risers	Flow in each part V_o (l/h)	Total flow V_c (l/h)
	In risers Q_r (W)	In header Q_h (W)	Total in each part (W)	ΣQ total (W)			
1	200	100	300	2400		36	412
2	200	100	300	2100	0.09	38	376
3	200	100	300	1800	0.1	40	339
4	200	100	300	1500	0.12	43	299
5	200	100	300	1200	0.14	47	256
6	200	100	300	900	0.18	52	210
7	200	100	300	600	0.25	63	157
8	200	100	300	300	0.4	94	94

- The total flow in the hot water circulation system is calculated using formula:

$$\dot{V} = \frac{\Sigma \dot{Q}}{r \cdot c_w \cdot \Delta t_{hw}}$$

$\Sigma \dot{Q}$ - total heat losses in installation, (kW)

thus:

$$\dot{V}_c^{total} = \frac{2.4}{1 \times 4.18 \times 5}$$

$$= 0.114 \text{ l/s} = 412 \text{ l/h}$$

The total flow in hot water circulation system is: 412 l/h - the circulation pump shall be sized for this flow.

- The flow in each riser is calculated using formula:

Flow in the riser number 1:

$$\dot{V}_0 = \dot{V}_c \times \frac{Q_0}{Q_0 + Q_p}$$

thus:

$$\dot{V}_0^1 = 412 \times \frac{200}{200 + 2100}$$

$$= 35.84 \text{ l/h} \approx 36 \text{ l/h}$$

Flow in remaining risers should be calculated in the same way.

- The pressure drop in the system
Following assumptions were made to simplify calculation:
 - Linear pressure drop, $p_l = 60 \text{ Pa/m}$
(Linear pressure is the same for all pipes)
 - Local pressure drop is equal to 33 % of total linear pressure drop, $p_r = 0.33 p_l$

thus:

$$p_r = 0.33 \times 60 = 19.8 \text{ Pa/m} \approx 20 \text{ Pa/m}$$

- For the calculation used

$$p_{basic} = p_r + p_l = 60 + 20 = 80 \text{ Pa/m}$$

- Local pressure drop across the MTCV is calculated on the basis of:

$$\Delta p_{MTCV} = \left(\frac{0.01 \times \dot{V}_0}{Kv} \right)^2$$

where:

Kv - according to fig. 19 page 10 in this case

$Kv = 0.366 \text{ m}^3/\text{h}$ for preset 50 °C

\dot{V}_0 - flow through the MTCV at the flow temperature 50 °C (l/h)

- When designed flow have been calculated, use the fig. 17 on page 9.

Please note:

during pressure drop calculation across the valve the temperature of circulation water has to be observed. MTCV - Multifunction Thermostatic Circulation Valve has variable Kv value which is dependent on two values: the preset temperature and the temperature of the flow temperature.

When the \dot{V}_0 and Kv are known, the pressure drop across MTCV is calculated using the following formula:

$$\Delta p_{MTCV} = \left(\frac{0.01 \times \dot{V}_0}{Kv} \right)^2$$

thus:

$$\Delta p_{MTCV} = \left(\frac{0.01 \times 94}{0.366} \right)^2 = 6.59 \text{ kPa}$$

$$\Delta p_{MTCV} = (0.01 \times 94 / 0.366)^2 = 6.59 \text{ kPa}$$

- Differential pressure across the pump:

$$*p_{pump} = \Delta p_{circuit} + \Delta p_{MTCV}$$

$$= 14.4 + 6.59 = 21 \text{ kPa}$$

Where:

$\Delta p_{circuit}$ - pressure drop in critical circuit (table 4)

* p_{pump} - includes pressure drop across all devices in circulation installation like: boiler, strainer etc.

Table 4

riser	pressure drop			across the MTCV		Total pressure pump (kPa)
	In risers	In header	$p_{circuit}$	V_0 -flow	Δp_{MTCV} pressure drop	
	(kPa)	(kPa)	(kPa)	(l/h)	(kPa)	
1	1.6	1.6	14.4	36	0.97	21
2	1.6	1.6	12.8	38	1.07	
3	1.6	1.6	11.2	40	1.19	
4	1.6	1.6	9.6	43	1.38	
5	1.6	1.6	8.0	47	1.64	
6	1.6	1.6	6.4	52	2.01	
7	1.6	1.6	4.8	63	2.96	
8	1.6	1.6	3.2	94	6.59	

Example of calculation

II Disinfection

The heat losses and pressure drop should be calculated according to new conditions.

- inlet hot water temperature during disinfection $T_{dis} = 70\text{ °C}$
- ambient temperature $*T_{amb} = 20\text{ °C}$ ($*T_{amb}$ - according to standard and norm obligatory)

1. The heat losses are calculated from the formula:

$$q_1 = K_j \times l \times \Delta T_1 \rightarrow K_j \times l = q_1 / \Delta T_1 \text{ for basic process}$$

$$q_2 = K_j \times l \times \Delta T_2 \rightarrow K_j \times l = q_2 / \Delta T_2$$

for disinfection process

Thus :

$$q_2 = q_1 \frac{\Delta T_2}{\Delta T_1} = q_1 \left(\frac{T_{dis} - T_{amb}}{T_{sup} - T_{amb}} \right)$$

for given case:

$$q_2 = 10 \text{ (W/m)} \left(\frac{70\text{ °C} - 20\text{ °C}}{55\text{ °C} - 20\text{ °C}} \right) = 14.3 \text{ W/m}$$

In this case during disinfection process heat losses increase for around 43 %.

2. Required flow

Due to sequence disinfection process (step by step) only critical circuit should be calculated.

For given case:

$$Q_{dis} = Q_c + Q_h$$

$$Q_{dis} = ((10+10) + (8 \times 10)) \times 14.3 \text{ W/m} = 1430 \text{ W} = 1.43 \text{ kW}$$

The flow:

$$\dot{V}_{dis} = \frac{1.43}{4.18 \times 5} = 0.0684 \text{ l/s} = 246 \text{ l/h}$$

3. The required pressure

The required pressure during the disinfection process should be checked

$$P_{dispump} = P_{dis(circuit)} + \Delta p_{MTCV}$$

where:

$$\Delta p_{MTCV} = \left(\frac{0.01 \times \dot{V}_0}{Kv} \right)^2$$

thus:

$$\Delta p_{MTCV} = \left(\frac{0.01 \times 246}{0.6} \right)^2 = 16.81 \text{ kPa}$$

Due to lower flow comparing to basic condition (412 l/h), pressure drop in the installation, $P_{circuit}$ should be recalculated.

$$\Delta p = \xi \frac{\rho w^2}{2}$$

where :

w - velocity of the water (m/s)

By comparing conditions during basic operation and disinfection one can estimate:

$$P_{dis} = P_{basic} \times \frac{V_{dis}^2}{V_c^2}$$

where :

V_{dis} - disinfection flow (l/h)

V_c - basic flow (l/h)

Thus:

- for first part of installation

$$P_{dis}^1 = 80 \times \left(\frac{246}{412} \right)^2 = 29 \text{ Pa/m}$$

This calculation should be done for all critical circuit. The table 5 shows the result of calculation.

For the critical circuit:

$$P_{dis(circuit)} = 0.57 + 0.68 + 0.84 + 1.08 + 1.48 + 2.20 + 3.93 + 21.92 = 32.70 \text{ kPa}$$

$$P_{dispump} = P_{dis(circuit)} + \Delta p_{MTCV} = 32.70 + 16.81 = 49.51 \text{ kPa}$$

The pump should be chosen to cover both requirements:

• basic operation, $\dot{V}_0 = 412 \text{ l/h}$ and $p_{pump} = 21 \text{ kPa}$

• disinfection operation $\dot{V}_0 = 246 \text{ l/h}$ and $P_{pump} = 49.51 \text{ kPa}$

Table 5

pressure drop the circuit during disinfection process					Total pressure drop in critical circuit
flow (l/h)		new pressure drop (Pa/m)	length (m)	pressure drop (kPa)	
basic	disinfection				
412	246	29	20	0.57	32.70
376	246	34	20	0.68	
339	246	42	20	0.84	
299	246	54	20	1.08	
256	246	74	20	1.48	
210	246	110	20	2.20	
157	246	196	20	3.93	
94	246	548	40	21.92	
$\Sigma 32.70$					

Dimensions

