



WM 015 DN 15

The Watts slide-in check valve type WM 015 features a noiseless operation, very low pressure loss and absolute sealing at high and low back pressures. The split valve stem principle guarantees a trouble free operation for many years.

Technical specifications

Working pres.	PN10
Testing pres.	1600 kPa
Closing pres.	10 cm wc
Max. temp.	up to 90 °C
Diam. nominal	DN 15

Approvals

KIWA	NL
ABP	D
DVGW	D
NF	F
WRAS	UK
ETA	DK
SITAC	S

Material specifications

House	POM
Valve	POM
Torpedo	POM
Diaphragm	Rubber
Spring	Stainless Steel

Other diameters and other closing pressures on request.

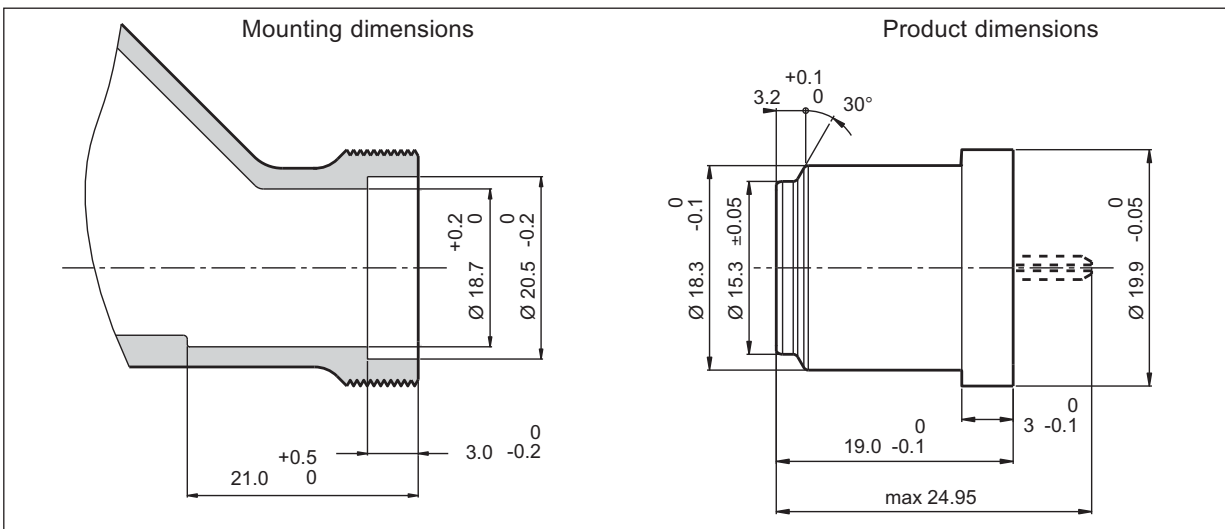

Pressure loss-curve

