

103

YORK® CHECK VALVE



SIZE	PRESSURE	CODE	PACKING
3/8" (DN 10)	12bar/174psi	1030038	10/200
1/2" (DN 15)	12bar/174psi	1030012	10/200
3/4" (DN 20)	12bar/174psi	1030034	8/128
1" (DN 25)	12bar/174psi	1030100	8/88
1*1/4 (DN 32)	10bar/145psi	1030114	6/54
1*1/2 (DN 40)	10bar/145psi	1030112	4/36
2" (DN 50)	10bar/145psi	1030200	2/28
2*1/2 (DN 65)	8bar/116psi	1030212	1/16
3" (DN 80)	8bar/116psi	1030300	1/12
4" (DN 100)	8bar/116psi	1030400	1/7

TECHNICAL SPECIFICATIONS

Body in brass.
 Plate in polymer.
 Washer in NBR.
 Spring in stainless steel.
 Minimum and maximum working temperatures: -20°C, 100°C.
 Threads: ISO228 (equivalent to DIN EN ISO 228 and BS EN ISO 228).

MATERIALS

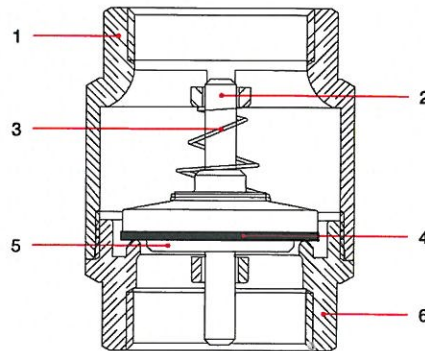

POS.	DESCRIPTION	N.	MATERIAL
1	Body	1	Bras CW617N
2	Pin	1	Polymer
3	Spring	1	Stainless steel AISI 302
4	Washer	1	NBR
5	Plate	1	Polymer
6	End adapter	1	Brass CW617N



OVERALL DIMENSIONS

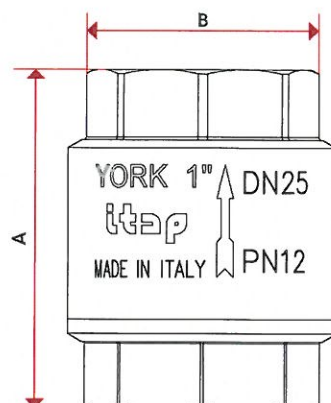

	3/8"	1/2"	3/4"	1"	1 1/4"	1 1/2"	2"	2 1/2"	3"	4"
DN	10	15	20	25	32	40	50	65	80	100
A	46,5	48	53	60,5	66,5	74	80,5	98	103	118,5
B	35	35	42	48	59,5	70,5	86	103	126	154
Kg/cm ² bar	12	12	12	12	10	10	10	8	8	8
LBS - psi	170	170	170	170	140	140	140	110	110	110

MANUFACTURER INSTRUCTIONS

Installation

The YORK® check valves are uni-directional; in the sense that they manage the flow in one direction only, which is indicated by the arrow on the body. The valves are composed by a spring, a little valve and a couple of parts made of brass (body and end-adapter) which contain them and that are assembled by means of thread and a sealed material to obtain their aim. In order to avoid that the sealed material gets broken and then the valve loses the connection between the body and the end-adapter, it's necessary to avoid to submit the two parts under the influence of a torque. For the installation normal hydraulic practices must be used, and especially:

- For a proper installation of the valve, near curves and circulation pumps, the valve must be mounted at a distance equal to 10 times the diameter of the pipe.
- The installer has to be sure that the two pipes are correctly allied;
- During the assembling process the installer has to apply its assembling tools at the end that is nearest to the pipe;
- The application of the sealing materials by the fitter (PTFE or hempen cloth) must be limited at the thread zone. An excess should interfere in the ball gas get's closure zone, compromising the tightness;
- In case the fluid transported has got some impurities (dust, too hard water, and so on) it's necessary to remove impurities by or filter them, otherwise they could damage the seal.

Disassembly the installed valve

To remove the valve from the pipe line or anyhow before unscrewing the connections linked:

- Wear the protective clothing normally required to work with carried fluids;
- Take the pressure inside the line out;
- During the disassembling process, apply the key at the end of the valve, the one nearest the pipe

Maintenance

Verify the valve periodically, according to its application's field and its works' field and its work's conditions, in order to be sure that the valve works correctly. In case of losses of tightening, take note that these can be caused by a deposit of foreign bodies (dirty, calcareous) on the rubber seal. In order to solve this inconvenient, it's necessary to unmount the valve and remove the foreign body with compressed air tools.

FLOW RATE WITH WATER AND PRESSURE DROP CHART

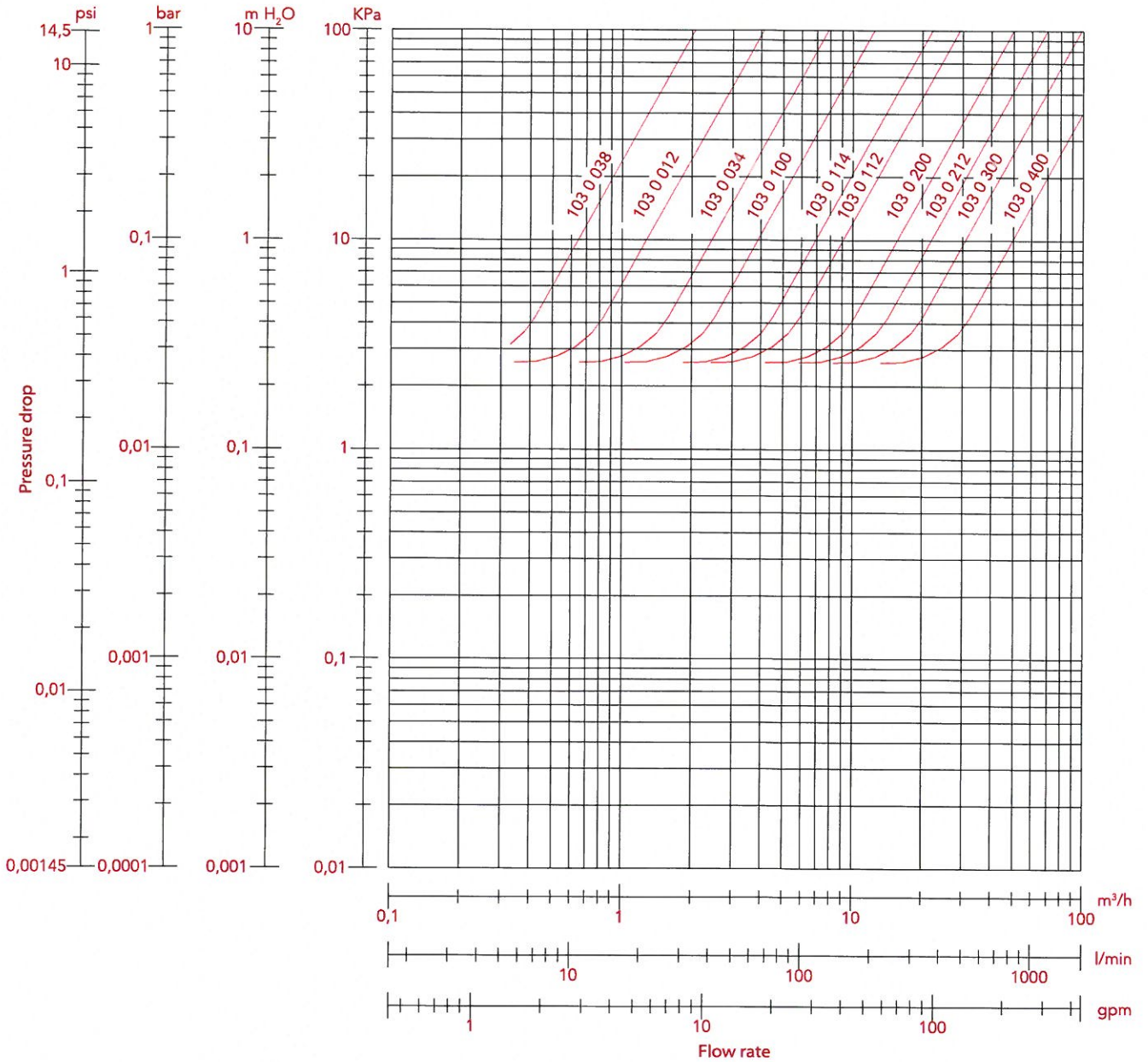

SIZE	3/8"	1/2"	3/4"	1"	1 1/4"	1 1/2"	2"	2 1/2"	3"	4"
Kv	2.11	4.22	7.92	11.67	22.42	29.39	51.40	69.90	98.49	157.91



DIAGRAM MINIMUM PRESSURE TO GET THE VALVES OPENING

